



Experience Communication in High Definition

LifeSize® SDI Adapter™



SDI Adapter for LifeSize® Room™

LifeSize® SDI Adapter™ is an easy-to-use hardware device designed to extend the benefits of third-party high definition videoconferencing cameras to the LifeSize® Room™ video communications solution.

Seamless integration with third-party videoconference cameras

The LifeSize SDI Adapter seamlessly connects with LifeSize Room, allowing both LifeSize and third-party cameras to be used simultaneously for dual camera capabilities. The first HD camera supported by the LifeSize SDI Adapter is the Sony EVI-HD1, and it's fully supported and controlled by the LifeSize remote control and LifeSize software.

Supported by the LifeSize SDI Adapter, the Sony HD cameras offers up to 10x optical zoom, making it ideal for large room environments such as auditoriums and lecture halls. The LifeSize SDI Adapter can support up to a 300 foot/90 meter cable run, allowing optimal camera and codec placement .

With the LifeSize SDI Adapter and third-party cameras, LifeSize Room can bring high definition visual communications to more rooms and more people - Everyone, Every room, Everywhere.

The Advantages are Clear

Expand your LifeSize options — Connect the LifeSize Room codec to third-party video cameras like the Sony EVI-HD1 HD Color PTZ Video Camera for a wider range of deployment options

Ideal for large room environments — The LifeSize SDI Adapter supports cable runs up to 300 feet/90 meters in length, allowing optimal camera position in large conference rooms.

Simple to Use — Plug and play operation, complete integration with LifeSize Room.

Cost Effective — Delivers a flexible third-party camera solution using the industry's most cost-effective multi-camera HD video codec.

Efficient, Compact Design — The LifeSize SDI Adapter is a small inline unit powered by the LifeSize Room Camera port. No external power supply or adapter is required.

Product Specifications - LifeSize® SDI Adapter™

System Components

LifeSize SDI Adapter

Cables

- LifeSize Camera cable (7.5m)
- HD-SDI RG6 (BNC to BNC) (15m)
- VISCA DB9f to 8 pin Mini DIN8 (25m)

Supported HD-SDI Formats

- SMTPE 292M@30Hz (720p30)
- SMTPE 292M@29.97Hz (720p29.97)
- SMTPE 292M@25Hz (720p25)

Video Formats

High Definition, 16x9 aspect ratio

Video Inputs

1 x SDI BNC (RG6 or equivalent)

Video Outputs

1 x LifeSize Camera port

VISCA Support

VISCA to DB9 (RS-232 port)
LifeSize Room system using supplied VISCA cable
Software supported on LifeSize Version 2.6.5 or above
Note: The VISCA port on the LifeSize SDI Adapter is reserved for future use

Power

Supplied by LifeSize Room Codec through LifeSize Camera cable

Environmental

Operating temperature:
0 °C (32°F) to 35°C (95°F)
Operating Humidity:
15% to 85%, non-condensing
Storage temperature:
-20°C (-4°F) to 60°C (140°F)
Storage Humidity:
10% to 90%, non-condensing

Regulatory Model Number

Model: LifeSize SDI Adapter = LFZ-008

For additional information:

www.lifesize.com/support

High Definition Camera

Supported third party camera:
Sony EVI-HD1 HD Color PTZ Video Camera
Support for single or dual cameras with LifeSize Room, one third-party camera per SDI Adapter

Sony EVI-HD1 Specifications

Video Signal Resolution 1280x720, 29.97 fps
10x Optical Zoom
40x with digital zoom
Wide angle zoom lens:
70 degree field of view
Auto/Manual focus
Automatic Gain Control
10 camera presets
Maximum Cable Length
SDI - 300 ft (100m)
Power
12 V DC (10.8 to 13.0 V DC)
Operating Temperature
0°C (32°F) to 40°C (104°F)
Camera dimensions
Width: 259 mm (10¼ in)
Depth: 150 mm (6¾ in)
Height: 169 mm (6¾ in)
Weight: 2 kg (4 lb 7 oz)

Supplied accessories:

- AC Adaptor (1), AC power cable (1), IR remote commander unit (1), Operating instructions (1)

Information contained in this document is preliminary and subject to change without notice. LifeSize is a registered trademark or trademark of LifeSize Communications in the U.S. and other countries. Copyright 2007. All rights reserved. October 2007.

LifeSize SDI Adapter Deployment Configuration

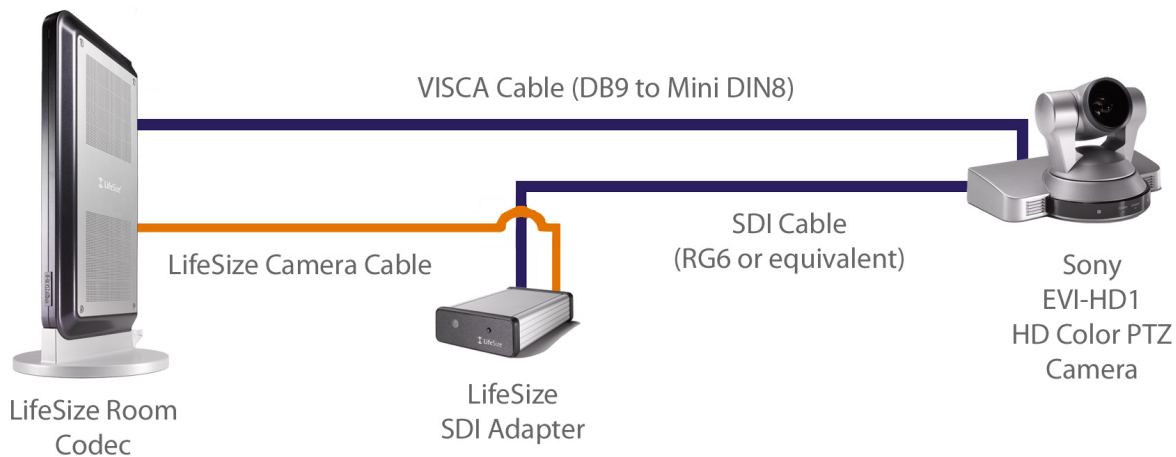

Corporate Headquarters:
901 S. Mopac Expressway
Building 3, Suite 300
Austin, Texas 78746 USA

Phone: +1 512 347 9300
Fax: +1 512 347 9301
Email: info@lifesize.com
www.lifesize.com

EMEA:
LifeSize Communications
United Kingdom
Phone: +44 1256 480 591

APAC:
LifeSize Communications
Hong Kong
Phone: +852 8239 3695